

MENIIT

NEET | IIT-JEE | FOUNDATION

Corporate Office: 44-A/1, Kalu Sarai, New Delhi 110016 | Web: www.meniit.com

JEE MAINS-2019

12-01-2019 Online (Morning)

IMPORTANT INSTRUCTIONS

1. The test is of 3 hours duration.
2. This Test Paper consists of **90 questions**. The maximum marks are 360.
3. There are three parts in the question paper A, B, C consisting of **Mathematics, Chemistry and Physics** having 30 questions in each part of equal weightage. Each question is allotted 4 (four) marks for correct response.
4. Out of the four options given for each question, only one option is the correct answer.
5. For each incorrect response 1 mark i.e. $\frac{1}{4}$ (one-fourth) marks of the total marks allotted to the question will be deducted from the total score. No deduction from the total score, however, will be made if no response is indicated for an item in the Answer Box.
6. Candidates will be awarded marks as stated above in instruction No.3 for correct response of each question. One mark will be deducted for indicating incorrect response of each question. No deduction from the total score will be made if no response is indicated for an item in the answer box.
7. There is only one correct response for each question. Marked up more than one response in any question will be treated as wrong response and marked up for wrong response will be deducted accordingly as per instruction 6 above..

PART-A-MATHEMATICS

1. If λ be the ratio of the roots of the quadratic equation in x , $3m^2x^2 + m(m-4)x + 2 = 0$, then the least value of m for which $\lambda + \frac{1}{\lambda} = 1$, is

(1) $-2 + \sqrt{2}$ (2) $2 - \sqrt{3}$ (3*) $4 - 3\sqrt{2}$ (4) $4 - 2\sqrt{3}$

Sol. Let roots are α and β now

$$\lambda + \frac{1}{\lambda} = 1 \Rightarrow \frac{\alpha}{\beta} + \frac{\beta}{\alpha} = 1 \Rightarrow \alpha^2 + \beta^2 = \alpha\beta$$

$$(\alpha + \beta)^2 = 2\alpha\beta$$

$$\left(\frac{-m(m-4)}{3m^2}\right)^2 = 3 \cdot \frac{2}{3m^2}$$

$$m^2 - 8m - 2 = 0$$

$$m = 4 \pm 3\sqrt{2}$$

So least value of $m = 4 - 3\sqrt{2}$

2. The maximum value of $3\cos\theta + 5\sin\left(\theta - \frac{\pi}{6}\right)$ for any real value of θ is

(1*) $\sqrt{19}$ (2) $\sqrt{34}$ (3) $\frac{\sqrt{79}}{2}$ (4) $\sqrt{31}$

Sol. $5\sin\left(\theta - \frac{\pi}{6}\right) + 3\cos\theta$

$$= 5\left(\sin\theta\cos\frac{\pi}{6} - \cos\theta\sin\frac{\pi}{6}\right) + 3\cos\theta$$

$$= \frac{5\sqrt{3}}{2}\sin\theta + \frac{1}{2}\cos\theta$$

$$\text{maximum value is } \sqrt{\left(\frac{5\sqrt{3}}{2}\right)^2 + \left(\frac{1}{2}\right)^2} = \sqrt{19}$$

3. Let C_1 and C_2 be the centres of the circles $x^2 + y^2 - 2x - 2y - 2 = 0$ and $x^2 + y^2 - 6x - 6y + 14 = 0$ respectively. If P and Q are the points of intersection of these circles, then the area (in sq. units) of the quadrilateral PC_1QC_2 is

(1) 8 (2) 6 (3*) 4 (4) 9

Sol. Since circles are orthogonal and have equal radii therefore the quadrilateral PC_1QC_2 is a square. Hence area = $2 \times 2 = 4$ sq. units

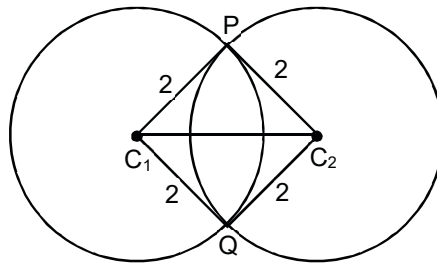

4. Let $y = y(x)$ be the solution of the differential equation, $x \frac{dy}{dx} + y = x \log_e x$, ($x > 1$).

If $2y(2) = \log_e 4 - 1$, then $y(e)$ is equal to

- (1) $-\frac{e}{2}$ (2) $\frac{e^2}{4}$ (3) $-\frac{e^2}{2}$ (4*) $\frac{e}{4}$

Sol. $\frac{dy}{dx} + \frac{1}{x} \cdot y = \ln x$

$\therefore I/F = e^{\int \frac{1}{x} dx} = e^{\ln x} = x$

$\therefore yx = \int x \cdot \ln x dx = \frac{x^2}{2} \ln x - \int \frac{1}{x} \cdot \frac{x^2}{2} dx$

$\therefore xy = \frac{x^2}{2} \ln x - \frac{x^2}{4} + c$

Put $x = 2$ & $y = \frac{1}{2}(\ln 4 - 1)$

$\Rightarrow \ln 4 - 1 = 2 \ln 2 - 1 + c \quad \therefore c = 0$

$\therefore y = \frac{x}{2} \ln x - \frac{x}{4}$

$\Rightarrow y = \frac{e}{2} - \frac{e}{4} = \frac{e}{4}$

5. The integral $\int \cos(\log_e x) dx$ is equal to (where C is a constant of integration)

- (1) $x[\cos(\log_e x) - \sin(\log_e x)] + C$ (2*) $\frac{x}{2}[\cos(\log_e x) + \sin(\log_e x)] + C$
 (3) $\frac{x}{2}[\sin(\log_e x) - \cos(\log_e x)] + C$ (4) $x[\cos(\log_e x) + \sin(\log_e x)] + C$

Sol. $I = \int \cos(\ln x) dx = \int 1 \cdot \cos(\ln x) dx$

$\therefore I = x \cdot \cos \ln x + \int x \cdot \sin \ln x \cdot \frac{1}{x} dx$

$\therefore I = x \cdot \cos (\ln x) + \int 1 \cdot \sin (\ln x) dx$

$\therefore I = x \cdot \cos (\ln x) + x \cdot \sin x (\ln x) - \int x \cdot \cos \ln x \cdot \frac{1}{x} dx$

$$\therefore 2I = x (\cos \ln x + \sin \ln x)$$

$$\therefore I = \frac{x}{2} (\cos \ln x + \sin \ln x) + C$$

6. If the straight line, $2x - 3y + 17 = 0$ is perpendicular to the line passing through the point $(7, 17)$ and $(15, \beta)$, then β equals :

- (1) -5 (2) $-\frac{35}{3}$ (3) $\frac{35}{3}$ (4*) 5

Sol. Line perpendicular to $2x - 3y + 5 = 0$ is $3x + 2y + c = 0$

Which is satisfied by point $(7, 17)$

$$\Rightarrow 3(7) + 2(17) + c = 0$$

$$\Rightarrow c = -55$$

$$\Rightarrow \text{equation of line is } 3x + 2y - 55 = 0$$

$$\Rightarrow 3(15) + 2(\beta) - 55 = 0$$

$$\Rightarrow 2\beta = 55 - 45 \Rightarrow \beta = 5$$

7. If the sum of the deviation of 50 observation from 30 is 50, then the mean of these observations is

- (1*) 31 (2) 50 (3) 51 (4) 30

Sol. $\sum_{i=1}^{50} (x_i - 30) = 50$

$$\Rightarrow \sum_{i=1}^{50} x_i - 30 \cdot 50 = 50$$

$$\Rightarrow \sum_{i=1}^{50} x_i - 30 = 1$$

$$\Rightarrow \bar{x} = 31$$

8. The perpendicular distance from the origin to the plane containing the two lines, $\frac{x+2}{3} = \frac{y-2}{5} = \frac{z+5}{7}$

and $\frac{x-1}{1} = \frac{y-4}{4} = \frac{z+4}{7}$, is

- (1) 11 (2*) $\frac{11}{\sqrt{6}}$ (3) $6\sqrt{11}$ (4) $11\sqrt{6}$

Sol. $\pi: \begin{vmatrix} x-1 & y-4 & z+4 \\ 3 & 5 & 7 \\ 1 & 4 & 7 \end{vmatrix} = 0$

$$\pi: 7x - 14y + 7z = -77$$

$$\pi: x - 2y + z + 11 = 0$$

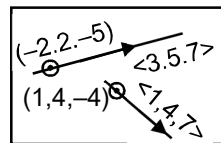

$$p = \left| \frac{11}{\sqrt{1^2 + 2^2 + 1^2}} \right| = \frac{11}{\sqrt{6}}$$

9. If $\frac{z-\alpha}{z+\alpha}$ ($\alpha \in \mathbb{R}$) is a purely imaginary number and $|z| = 2$, then a value of α is

- (1) $\sqrt{2}$ (2*) 2 (3) $\frac{1}{2}$ (4) 1

Sol. $\left(\frac{z-\alpha}{z+\alpha} \right) = -\left(\frac{\bar{z}-\alpha}{\bar{z}+\alpha} \right)$
 $\Rightarrow z\bar{z} + \alpha z - \alpha\bar{z} - \alpha^2 = -(z\bar{z} - \alpha z + \alpha\bar{z} - \alpha^2)$
 $\Rightarrow z\bar{z} + \alpha\bar{z} - \alpha\bar{z} - \alpha^2 + z\bar{z} - \alpha z + \alpha\bar{z} - \alpha^2 = 0$
 $\Rightarrow z\bar{z} = \alpha^2 \Rightarrow a^2 = |z|^2 = 4$
 $\Rightarrow \alpha = \pm 2$

10. Let S be the set of all points in $(-\pi, \pi)$ at which the function, $f(x) = \min. \{ \sin x, \cos x \}$ is not differentiable. Then S is a subset of which of the following?

- (1) $\left\{ -\frac{\pi}{4}, 0, \frac{\pi}{4} \right\}$ (2) $\left\{ -\frac{3\pi}{4}, -\frac{\pi}{2}, \frac{\pi}{2}, \frac{3\pi}{4} \right\}$ (3) $\left\{ -\frac{\pi}{2}, -\frac{\pi}{4}, \frac{\pi}{4}, \frac{\pi}{2} \right\}$ (4*) $\left\{ -\frac{3\pi}{4}, -\frac{\pi}{4}, \frac{3\pi}{4}, \frac{\pi}{4} \right\}$

Sol. $\therefore x = \left\{ -\frac{3\pi}{4}, \frac{\pi}{4} \right\}$

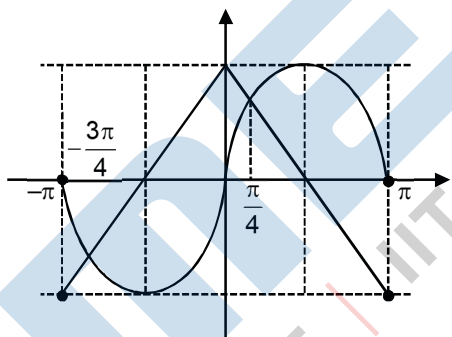

11. If a variable line, $3x + 4y - \lambda = 0$ is such that the two circles $x^2 + y^2 - 2x - 2y + 1 = 0$ and $x^2 + y^2 - 18x - 2y + 78 = 0$ are on its opposite sides, then the set of all values of λ is the interval

- (1) [13, 23] (2) (2, 17) (3*) [12, 21] (4) (23, 31)

Sol. $3x + 4y - \lambda = 0$
 $(7 - \lambda)(31 - \lambda) < 0$ (since centres lie opposite side)
 $\lambda \in (7, 31)$ (1)

$$\left| \frac{7-\lambda}{5} \right| \geq 1 \text{ and } \left| \frac{31-\lambda}{5} \right| \geq 2$$

$$|7 - \lambda| \geq 5 \text{ and } |31 - \lambda| \geq 10$$

$$\lambda \leq 2 \text{ or } \lambda \geq 12 \dots\dots\dots(2)$$

$$\text{and } \lambda \leq 21 \text{ or } \lambda \geq 41 \dots\dots\dots(3)$$

$$(1) \cap (2) \cap (3)$$

$$\lambda \in [12, 21]$$

12. Let f and g be continuous function on [0, a] such that f(x) = f(a - x) and g(x) + g(a - x) = 4, then

$\int_0^a f(x)g(x)dx$ is equal to

(1) $\int_0^a f(x)dx$

(2) $4 \int_0^a f(x)dx$

(3*) $2 \int_0^a f(x)dx$

(4) $-3 \int_0^a f(x)dx$

Sol. $I = \int_0^a f(x)g(x)dx$

& $I = \int_0^a f(a-x)g(a-x)dx$

$$2I = \int_0^a f(x) \cdot 4 dx$$

$$\therefore I = 2 \int_0^a f(x) dx$$

13. Considering only the principal values of inverse function the set :

$$A = \left\{ x \geq 0; \tan^{-1}(2x) + \tan^{-1}(3x) = \frac{\pi}{4} \right\}$$

(1) contains more than two elements

(2) contains two elements

(3*) is a singleton

(4) is an empty set

Sol. $\frac{2x + 3x}{1 - 2x \cdot 3x} = 1$

$$\Rightarrow 5x = 1 - 6x^2$$

$$\Rightarrow 6x^2 + 5x - 1 = 0 \Rightarrow x = \frac{1}{6} \text{ or } x = -1 \text{ (Rejected)}$$

14. For $x > 1$, if $(2x)^{2y} = 4 e^{2x-2y}$, then $(1 + \log_e 2x)^2 \frac{dy}{dx}$ is equal to

(1) $\frac{x \log_e 2x + \log_e 2}{x}$ (2*) $\frac{x \log_e 2x - \log_e 2}{x}$ (3) $\log_e 2x$ (4) $x \log_e 2x$

Sol. $2y \cdot \ln(2x) = \ln 4 + 2x - 2y$
 $\Rightarrow 2y(1 + \ln(2x)) = 2x + \ln 4 = 2x + 2 \ln 2$

$\Rightarrow y = \frac{x + \ln 2}{1 + \ln(2x)}$

$\Rightarrow \frac{dy}{dx} = \frac{1 \cdot (1 + \ln 2x) - \frac{2}{2x} (x + \ln 2)}{(1 + \ln 2x)^2}$

$\Rightarrow \frac{dy}{dx} = \frac{1 + \ln 2x - 1 - \frac{1}{x} \ln 2}{(1 + \ln 2x)^2}$

$\Rightarrow (1 + \ln 2x)^2 \cdot \frac{dy}{dx} = \frac{x \cdot \ln 2x - \ln 2}{x}$

15. If the vertices of a hyperbola be at $(-2, 0)$ and $(2, 0)$ and one of its foci be at $(-3, 0)$, then which one of the following points does not lie on this hyperbola?

(1) $(2\sqrt{6}, 5)$ (2*) $(6, 5\sqrt{2})$ (3) $(4, \sqrt{15})$ (4) $(-6, 2\sqrt{10})$

Sol. $a = 2$ and $ae = 3$

$2e = 3 \Rightarrow e = \frac{3}{2}$

$\therefore e^2 = 1 + \frac{b^2}{a^2} \Rightarrow \frac{9}{4} = 1 + \frac{b^2}{4}$

$\therefore \frac{b^2}{4} = \frac{5}{4} \Rightarrow b^2 = 5$

$\therefore H: \frac{x^2}{4} - \frac{y^2}{5} = 1$

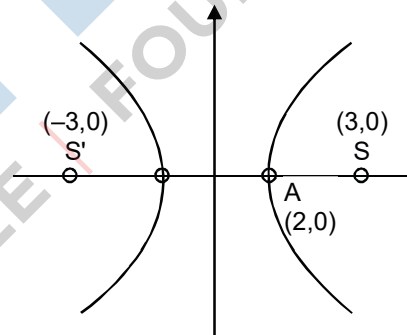

(1) $(2\sqrt{6}, 5) \Rightarrow 6 - 5 = 1$ lies on hyperbola

(2) $(6, 5\sqrt{2}) \Rightarrow 9 - 10 = -1$

(3) $(4, \sqrt{15}) \Rightarrow 4 - 3 = 1$ lies on hyperbola

(4) $(-6, 2\sqrt{10}) \Rightarrow 9 - 8 = 1$ lies on hyperbola

16. A ratio of the 5th term from the beginning to the 5th term from the end in the binomial expansion of

$\left(2^{\frac{1}{3}} + \frac{1}{2(3)^{\frac{1}{3}}}\right)^{10}$ is

- (1) $1:4(16)^{\frac{1}{3}}$ (2*) $4(36)^{\frac{1}{3}}:1$ (3) $1:2(6)^{\frac{1}{3}}$ (4) $2(36)^{\frac{1}{3}}:1$

Sol.
$$\frac{5^{\text{th}} \text{ term from begining}}{5^{\text{th}} \text{ term from end}} = \frac{{}^{10}C_4 \left(\frac{1}{2(3^{1/3})} \right)^4 2^{6/3}}{{}^{10}C_4 (2)^{4/3} \left(\frac{1}{2(3^{1/3})} \right)^6}$$

$$= \frac{2^2 2^2 3^{-4/3}}{2^4 2^{(4/3)-6m^2}} = 3^{2/3} \cdot 2^{8/3} = 4 \cdot (36)^{1/3}$$

17. Let $P = \begin{bmatrix} 1 & 0 & 0 \\ 3 & 1 & 0 \\ 9 & 3 & 1 \end{bmatrix}$ and $Q = [q_{ij}]$ be two 3×3 matrices such that $Q - P^5 = I_3$. Then $\frac{q_{21} + q_{31}}{q_{32}}$ is equal to

- (1) 15 (2) 135 (3*) 10 (4) 9

Sol. $Q = P^5 + I_3$

$$Q = \begin{bmatrix} 1 & 0 & 0 \\ 15 & 1 & 0 \\ 135 & 15 & 1 \end{bmatrix} = \begin{bmatrix} 1 & 0 & 0 \\ 0 & 1 & 0 \\ 0 & 0 & 1 \end{bmatrix}$$

$$Q = \begin{bmatrix} 2 & 0 & 0 \\ 15 & 2 & 0 \\ 135 & 15 & 2 \end{bmatrix}$$

$$\therefore \frac{q_{21} + q_{31}}{q_{32}} = \frac{15 + 135}{15} = 1 + 9 = 10$$

18. Let $S_k = \frac{1+2+3+\dots+k}{k}$. If $S_1^2 + S_2^2 + \dots + S_{10}^2 = \frac{5}{12}A$, then A is equal to

- (1) 283 (2) 301 (3*) 303 (4) 156

Sol. $S_k = \frac{k+1}{2}$

$$\sum_{k=1}^{10} \left(\frac{k+1}{2} \right)^2 = \frac{5}{12}A$$

$$2^2 + 3^2 + \dots + 11^2 = \frac{5A}{3}$$

$$\frac{11 \times 12 \times 23}{6} - 1 = \frac{5A}{3}$$

$$505 \times \frac{3}{5} = A$$

$$A = 303$$

19. An ordered pair (α, β) for which the system of linear equations

$$(1 + \alpha)x + \beta y + z = 2$$

$$\alpha x + (1 + \beta)y + z = 3$$

$$\alpha x + \beta y + 2z = 2$$

has a unique solution, is

(1) $(-3, 1)$

(2*) $(2, 4)$

(3) $(-4, 2)$

(4) $(1, -3)$

Sol.
$$\Delta = \begin{vmatrix} 1+\alpha & \beta & 1 \\ \alpha & 1+\beta & 1 \\ \alpha & \beta & 2 \end{vmatrix} = \begin{vmatrix} 1 & -1 & 0 \\ 0 & 1 & -1 \\ \alpha & \beta & 2 \end{vmatrix}$$

$$\therefore \Delta = \begin{vmatrix} 1 & 0 & 0 \\ 0 & 1 & -1 \\ \alpha & \alpha+\beta & 2 \end{vmatrix} = 1(2 + \alpha + \beta)$$

$$\therefore \Delta = \alpha + \beta = 2 \neq 0$$

$$\therefore (2, 4) \text{ Ans.}$$

20. The product of three consecutive terms of a G.P. is 512. If 4 is added to each of the first and the second of these terms, the three terms now form an A.P. Then the sum of the original three terms of the given G.P. is

(1) 32

(2) 36

(3*) 28

(4) 24

Sol. Let the numbers be $\frac{a}{r}, a, ar$

$$\text{Given } a^3 = 512 \Rightarrow a = 8$$

Now given $\frac{8}{r} + 4, 12, 8r$ are in A.P.

$$\Rightarrow 2r^2 - 5r + 2 = 0$$

$$\Rightarrow r = \frac{1}{2} \text{ or } 2$$

Numbers are 4, 8, 16 or 16, 8, 4

$$\text{Sum of numbers} = 4 + 8 + 16 = 28$$

21. $\lim_{x \rightarrow \frac{\pi}{4}} \frac{\cot^3 x - \tan x}{\cos\left(x + \frac{\pi}{4}\right)}$ is

(1) $4\sqrt{2}$

(2) $8\sqrt{2}$

(3*) 8

(4) 4

Sol. $\lim_{x \rightarrow \frac{\pi}{4}} \frac{1 - \tan^4 x}{\cos x - \sin x} \cdot \sqrt{2}$

$$\begin{aligned}
 &= \lim_{x \rightarrow \frac{\pi}{4}} \frac{(\cos x)^4 - (\sin x)^4}{\cos x - \sin x} \cdot \frac{\sqrt{2}}{(\cos x)^4} \\
 &= \lim_{x \rightarrow \frac{\pi}{4}} 4\sqrt{2} \cdot \frac{(\cos^2 x - \sin^2 x)(\cos^2 x + \sin^2 x)}{\cos x - \sin x} \\
 &= 4\sqrt{2} \cdot \left(\frac{1}{\sqrt{2}} + \frac{1}{\sqrt{2}} \right) = 4\sqrt{2} \cdot \frac{2}{\sqrt{2}} = 8
 \end{aligned}$$

22. Consider three boxes, each containing 10 balls labelled 1, 2,, 10. Suppose one ball is randomly drawn from each of the boxes. Denote by n_i , the label of the ball drawn from the i^{th} box, ($i = 1, 2, 3$). Then, the number of ways in which the balls can be chosen such that $n_1 < n_2 < n_3$ is

- (1) 240 (2) 82 (3) 164 (4*) 120

Sol. $N = {}^{10}C_3 = \frac{10 \cdot 9 \cdot 8}{1 \cdot 2 \cdot 3} = 120$

23. Let $S = \{1, 2, 3, \dots, 100\}$. The number of non-empty subsets A of S such that the product of elements in A is even is

- (1*) $2^{50}(2^{50} - 1)$ (2) $2^{100} - 1$ (3) $2^{50} + 1$ (4) $2^{50} - 1$

Sol. Product is even when atleast one element of subset is even Hence required number of subsets = total subsets – number of subsets all whose elements are odd
 $= 2^{100} - 2^{50}$

24. The sum of the distinct real values of μ , for which the vectors $\mu \hat{i} + \hat{j} + \hat{k}, \hat{i} + \mu \hat{j} + \hat{k}, \hat{i} + \hat{j} + \mu \hat{k}$ are co-planar, is

- (1) 0 (2) 1 (3*) -1 (4) 2

Sol. $\begin{vmatrix} \mu & 1 & 1 \\ 1 & \mu & 1 \\ 1 & 1 & \mu \end{vmatrix} = 0 \Rightarrow (\mu - 1)^2 (\mu + 2) = 0$
 $\therefore \mu = 1, -2$

25. Let $P(4, -4)$ and $Q(9, 6)$ be two points on the parabola, $y^2 = 4x$ and let X be any point on the arc POQ of this parabola, where O is the vertex of this parabola, where O is the vertex of this parabola, such that the area of ΔPXQ is maximum. Then this maximum area (in sq. units) is :

- (1) $\frac{625}{4}$ (2) $\frac{125}{2}$ (3*) $\frac{125}{4}$ (4) $\frac{75}{2}$

Sol. $\Delta = \frac{1}{2} \begin{vmatrix} t^2 & 2t & 1 \\ 9 & 6 & 1 \\ 4 & -4 & 1 \end{vmatrix}$

$$\Delta = \frac{1}{2}(10t^2 - 2t \cdot 5 - 60)$$

$$\Delta = 5t^2 - 5t - 30$$

$$\Delta = |5(t^2 - t - 6)| ; t \in (-2, 3)$$

$$\therefore \frac{d\Delta}{dt} = 5(2t - 1) = 10 \left(t - \frac{1}{2} \right)$$

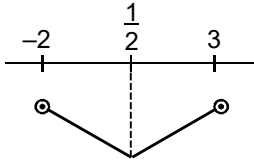

$$\Delta(t = 3) = |5(9 - 3 - 6)| = 0$$

$$\Delta(t = -2) = |5(4 + 2 - 6)| = 0$$

$$\left| \Delta \left(t = \frac{1}{2} \right) \right| = \left| 5 \left(\frac{1}{4} - \frac{1}{2} - 6 \right) \right| = \left| 5 \left(-\frac{1}{4} - 6 \right) \right| = \left| -5 \left(\frac{25}{4} \right) \right| = \frac{125}{4}$$

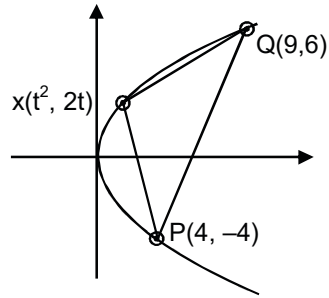

26. The area (in sq. units) of the region bounded by the parabola, $y = x^2 + 2$ and the lines, $y = x + 1$, $x = 0$ and $x = 3$, is

(1) $\frac{17}{4}$

(2*) $\frac{15}{2}$

(3) $\frac{21}{2}$

(4) $\frac{15}{4}$

Sol. $A = \int_0^3 (x^2 - x + 1) dx$

$$A = \left(\frac{x^3}{3} - \frac{x^2}{2} + x \right)_0^3$$

$$\therefore A = 9 - \frac{9}{2} + 3 = 12 - \frac{9}{2}$$

$$\therefore A = \frac{15}{2}$$

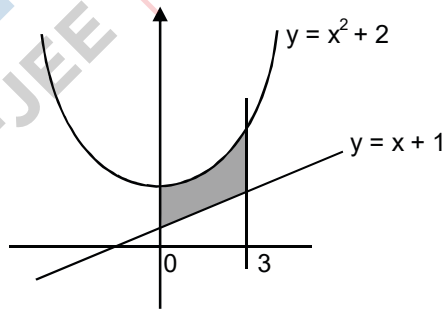

27. The Boolean expression $((p \wedge q) \vee (p \vee \sim q)) \wedge (\sim p \wedge \sim q)$ is equivalent to

(1) $p \vee (\sim q)$

(2) $p \wedge q$

(3*) $(\sim p) \wedge (\sim q)$

(4) $p \wedge (\sim q)$

	p	q	$\sim p$	$\sim q$	$p \wedge q$	$p \vee \sim q$	$(p \wedge q) \vee (p \vee \sim q)$ ^(A)	$\sim (p \vee q)$ ^(B)	$(A \wedge B)$
Sol.	T	T	F	F	T	T	T	F	F
	T	F	F	T	F	T	T	F	F
	F	T	T	F	F	F	F	F	F
	F	F	T	T	F	T	T	T	T

∴ (3) is correct

28. The maximum area (in sq. units) of a rectangle having its base on the x-axis and its other two vertices on the parabola, $y = 12 - x^2$ such that the rectangle lies inside the parabola, is

- (1) $18\sqrt{3}$ (2) 36 (3*) 32 (4) $20\sqrt{2}$

Sol. $A = 2x \cdot (12 - x^2)$

$A = 24x - 2x^3$; $x \in (0, 2\sqrt{3})$

$\frac{dA}{dx} = 24 - 6x^2 = 6(4 - x^2)$

$= -6(x - 2)(x + 2)$

∴ A is max at $x = 2$

∴ $A = 2 \cdot 2 \cdot (12 - 4) = 4 \cdot 8 = 32$

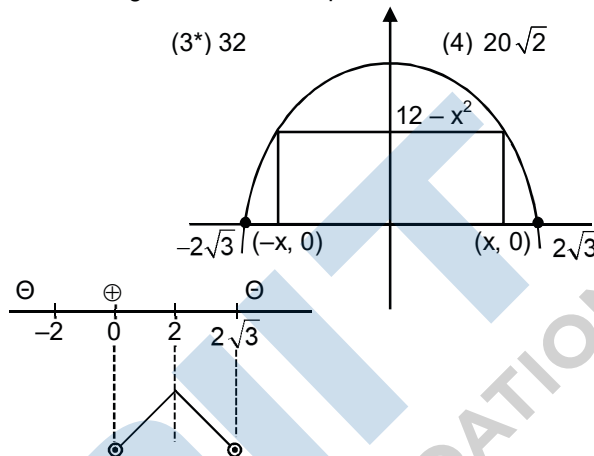

29. A tetrahedron has vertices $P(1, 2, 1)$, $Q(2, 1, 3)$, $R(-1, 1, 2)$ and $O(0, 0, 0)$. The angle between the faces OPQ and PQR is

- (1) $\cos^{-1}\left(\frac{7}{31}\right)$ (2*) $\cos^{-1}\left(\frac{19}{35}\right)$ (3) $\cos^{-1}\left(\frac{9}{35}\right)$ (4) $\cos^{-1}\left(\frac{17}{31}\right)$

Sol. Normal to face OPQ is $\vec{n}_1 = \begin{vmatrix} \hat{i} & \hat{j} & \hat{k} \\ 1 & 2 & 1 \\ 2 & 1 & 3 \end{vmatrix} \equiv \langle 5, -1, -3 \rangle$

Normal to face PQR is $\vec{n}_2 = \begin{vmatrix} \hat{i} & \hat{j} & \hat{k} \\ 1 & -1 & 3 \\ -2 & -1 & 1 \end{vmatrix} \equiv \langle 1, -5, -3 \rangle$

$\cos \theta = \left| \frac{5 + 5 + 9}{35} \right| = \frac{19}{35}$

30. In a random experiment, a fair die is rolled until two fours are obtained in succession. The probability that the experiment will end in the fifth throw of the die is equal to :

- (1) $\frac{150}{6^5}$ (2) $\frac{200}{6^5}$ (3) $\frac{225}{6^5}$ (4*) $\frac{175}{6^5}$

Sol. $\square - \square - \square - \square - 4 - 4$ ∴ $P = \frac{5 \cdot 1 \cdot 5 \cdot 1 \cdot 1 + 6 \cdot 5 \cdot 5 \cdot 1 \cdot 1}{6^5}$

∴ $P = \frac{175}{6^5}$

PART-B-CHEMISTRY

31. In the following reactions, products A and B are :

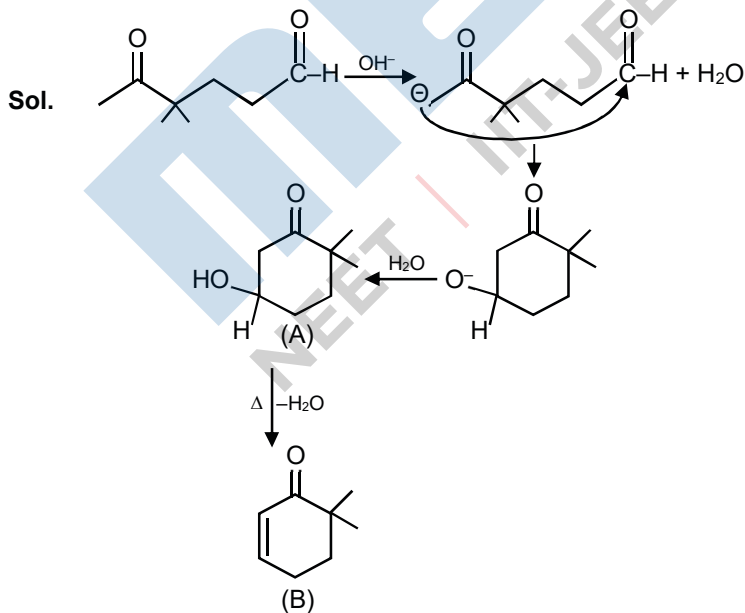
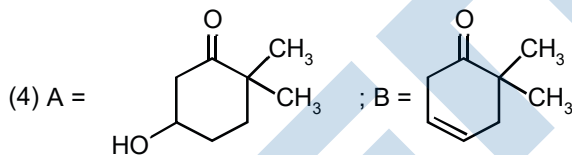
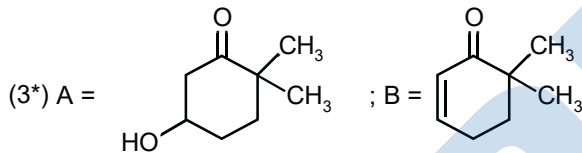
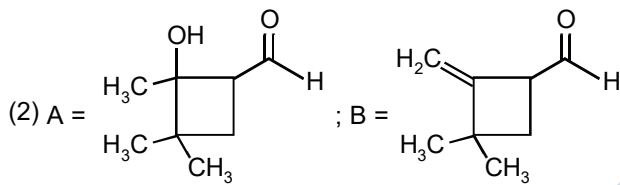
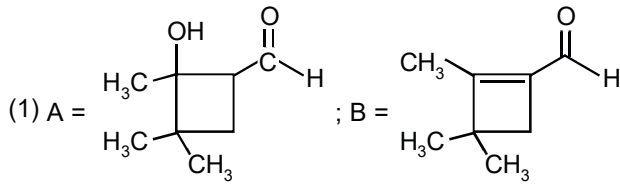
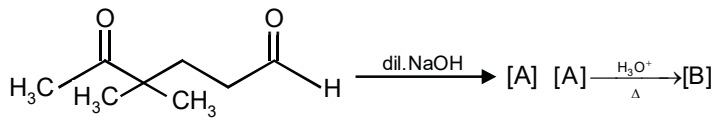

32. For a diatomic ideal gas in a closed system, which of the following plots does not correctly describe the relation between various thermodynamics quantities ?

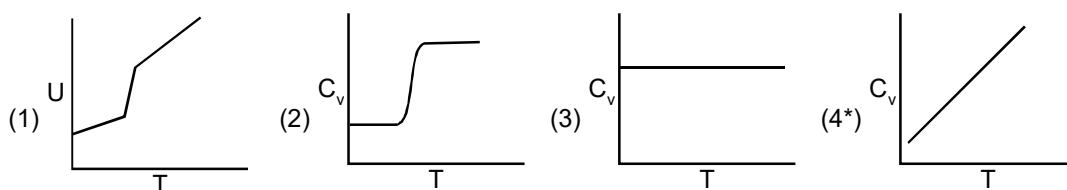

Sol. C_p does not change with change in pressure

33. What is the work function of the metal if the light of wavelength 4000\AA generates photoelectrons of velocity $6 \times 10^5 \text{ ms}^{-1}$ from it ?

(Mass of electron = $9 \times 10^{-31} \text{ kg}$, Velocity of light = $3 \times 10^8 \text{ ms}^{-1}$,

Planck's constant = $6.626 \times 10^{-34} \text{ Js}$, Charge of electron = $1.6 \times 10^{-19} \text{ J eV}^{-1}$)

- (1) 3.1 eV (2*) 2.1 eV (3) 4.0 eV (4) 0.9 eV

Sol. $h\nu = \phi + \frac{1}{2}mv^2$

$$\frac{1}{2}mv^2 = hc \left(\frac{1}{\lambda} - \frac{1}{\lambda_0} \right)$$

$$h\nu = \phi + \frac{1}{2}mv^2$$

$$\phi = \frac{6.626 \times 10^{-34} \times 3 \times 10^8}{4000 \times 10^{-10}} - \frac{1}{2} \times 9 \times 10^{-31} \times (6 \times 10^5)^2$$

$$\phi = 3.35 \times 10^{-19} \text{ J} \Rightarrow \phi \approx 2.1 \text{ eV}$$

34. The molecule that has minimum / no role in the formation of photochemical smog, is :

- (1*) NO (2) $\text{CH}_2 = \text{O}$ (3*) N_2 (4) O_3

Sol. Photochemical smog is produced when ultraviolet light from sun reacts with oxides of nitrogen in atmosphere.

35. Poly- β -hydroxybutyrate-co- β -hydroxy valerate (PHBV) is a copolymer of _____

- (1) 2-hydroxybutanoic acid and 3-hydroxypentanoic acid
 (2*) 3-hydroxybutanoic acid and 3-hydroxypentanoic acid
 (3) 2-hydroxybutanoic acid and 4-hydroxypentanoic acid
 (4) 3-hydroxybutanoic acid and 2-hydroxypentanoic acid

Sol. PHBV is obtained by copolymerization of 3-Hydroxybutanoic acid & 3-Hydroxypentanoic acid.

36. Freezing point of a 4 % aqueous solution of X is equal to freezing point of 12% aqueous solution of Y. If molecular weight of X is A, then molecular weight of Y is :

(1) A (2) 4A (3*) 3A (4) 2A

Sol. $(\Delta T_f)_x = (\Delta T_f)_y$

$$k_f m_x = k_f m_y$$

$$\frac{4 \times 1000}{A \times 96} = \frac{12 \times 1000}{M \times 88}$$

$$M = 3.27 A = 3A$$

37. In the following reaction

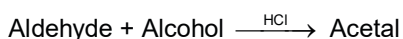

Aldehyde Alcohol

HCHO ^tBuOH

CH₃CHO MeOH

The best combination is :

(1) HCHO and ^tBuOH

(2) CH₃CHO and MeOH

(3*) HCHO and MeOH

(4) CH₃CHO and ^tBuOH

Sol. Rate $\propto \frac{1}{\text{Steric Crowding}}$

38. $\text{CH}_3\text{CH}_2 - \overset{\text{OH}}{\underset{\text{Ph}}{\text{C}}} - \text{CH}_3$ can not be prepared by :

(1) PhCOCH₃ + CH₃CH₂MgX

(2) HCHO + PhCH(CH₃)CH₂MgX

(3) PhCOCH₂CH₃ + CH₃MgX

(4*) CH₃CH₂COCH₃ + PhMgX

Sol. The reaction in option (A) will yield 1o-alcohol.

39. Two solids dissociate as follows

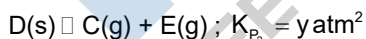
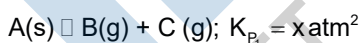

The total pressure when both the solids dissociate simultaneously is :

(1) $\sqrt{x+y}$ atm

(2*) $(x+y)$ atm

(3) $x^2 + y^2$ atm

(4) $2(\sqrt{x+y})$ atm

Sol. $A(s) \rightleftharpoons B(g) + C(g) \quad K_{P_1} = x \text{ atm}^2$

$D(s) \rightleftharpoons C(g) + E(g) \quad K_{P_2} = y \text{ atm}^2$

$$K_{P_1} = P_1(P_1 + P_2)$$

$$k_{P_2} = P_2(P_1 + P_2)$$

$$k_{P_1} = k_{P_2} = (P_1 + P_2)^2$$

$$X + y(P_1 + P_2)^2$$

$$P_1 + P_2 = \sqrt{x + y}$$

$$2(P_1 + P_2) = \sqrt{x + y}$$

$$P_{\text{Total}} = P_B + P_C + P_E = 2(P_1 + P_2) = \sqrt{x + y}$$

40. The hardness of a water sample (in terms of equivalents of CaCO_3) containing 10^{-3} M CaSO_4 is :

(Molar mass of $\text{CaSO}_4 = 136 \text{ g mol}^{-1}$)

(1) 50 ppm

(2) 10 ppm

(3*) 100 ppm

(4) 90 ppm

- Sol. As 1L solution have $10^{-3} \text{ mol CaSO}_4$

Eq. of $\text{CaSO}_4 = \text{eq. of CaCO}_3$

In 1L solution

$$n_{\text{CaSO}_4} = v.f. = n_{\text{CaCO}_3} \times v.f.$$

$$10^{-3} \times 2 = n_{\text{CaCO}_3} \times 2$$

$$n_{\text{CaCO}_3} = 10^{-3} \text{ mol in 1L}$$

$$\therefore w_{\text{CaCO}_3} = 100 \times 10^{-3} \text{ g in 1L solution}$$

\therefore hardness in terms of CaCO_3

$$= \frac{w_{\text{CaCO}_3}}{w_{\text{Total}}} \times 10^6 = \frac{100 \times 10^{-3} \text{ g}}{1000 \text{ g}} \times 10^6 = 100 \text{ ppm}$$

41. The volume of gas A is twice than that of gas B. The compressibility factor of gas A is thrice than that of gas B at same temperature. The pressures of the gases for equal number of moles are:

(1) $P_A = 3P_B$

(2) $P_A = 2P_B$

(3*) $2P_A = 3P_B$

(4) $3P_A = 2P_B$

- Sol. $Z = PV/nRT$

$$P = \frac{ZnRT}{V}$$

at constant T and mol $P \propto \frac{Z}{V}$

$$\frac{P_A}{P_B} = \frac{Z_A}{Z_B} \times \frac{V_B}{V_A} = \left(\frac{3}{1}\right) \times \left(\frac{1}{2}\right) = \frac{3}{2}$$

$$\therefore 2P_A = 3P_B$$

42. The correct order for acid strength of compounds $\text{CH}\equiv\text{CH}$, $\text{CH}_3-\text{C}\equiv\text{CH}$ and $\text{CH}_2=\text{CH}_2$ is as follows :

- (1) $\text{CH}_3-\text{C}\equiv\text{CH} > \text{CH}\equiv\text{CH} > \text{CH}_2=\text{CH}_2$
 (2) $\text{CH}\equiv\text{CH} > \text{CH}_2=\text{CH}_2 > \text{CH}_3-\text{C}\equiv\text{CH}$
 (3*) $\text{HC}\equiv\text{CH} > \text{CH}_3-\text{C}\equiv\text{CH} > \text{CH}_2=\text{CH}_2$
 (4) $\text{CH}_3-\text{C}\equiv\text{CH} > \text{CH}_2=\text{CH}_2 > \text{HC}\equiv\text{CH}$

Sol. Acidic strength \propto Stability of conjugate base
 E.N. \rightarrow sp carbon $>$ sp² carbon $>$ sp³ carbon

43. The metal d-orbitals that are directly facing the ligands in $\text{K}_3[\text{Co}(\text{CN})_6]$ are:

- (1) d_{xy} , d_{xz} and d_{yz} (2) d_{xz} , d_{yz} and d_{z^2} (3) d_{xy} and $d_{x^2-y^2}$ (4*) $d_{x^2-y^2}$ and d_{z^2}

Sol. Given $\text{K}_3[\text{Co}(\text{CN})_6]$ is inner orbital complex with hybridization d^2sp^3 and octahedral geometry. Ligands are approaching metal along the axes. Hence, $d_{x^2-y^2}$, d_{z^2} orbitals are directly in front of the ligands.

44. Which of the following has lowest freezing point?

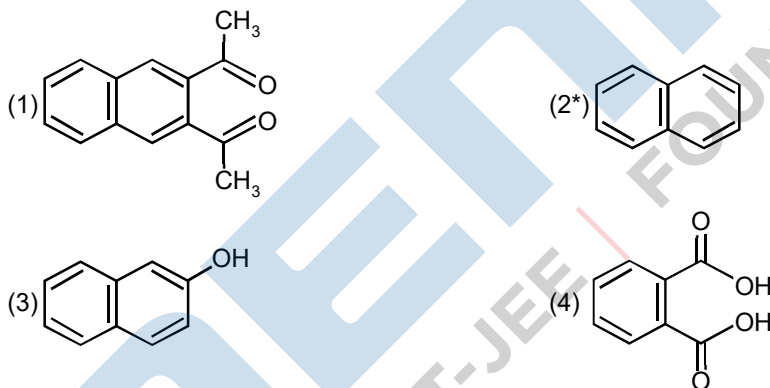

Sol. Stronger intermolecular forces result in higher melting point.

45. The standard electrode potential E^\ominus and its temperature coefficient $\left(\frac{dE^\ominus}{dT}\right)$ for a cell are 2 V and $-5 \times 10^{-4} \text{ VK}^{-1}$ at 300 K respectively. The cell reaction is

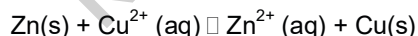

The standard reaction enthalpy ($\Delta_r H^\ominus$) at 300 K in kJ mol^{-1} is,

[Use $R = 8 \text{ JK}^{-1} \text{ mol}^{-1}$ and $F = 96,000 \text{ C mol}^{-1}$]

- (1) 206.4 (2*) -412.8 (3) 192.0 (4) -384.0

Sol. $\Delta G = -nFE_{\text{Cell}} = -2 \times 96500 \times 2 = -386 \text{ kJ}$

$$\Delta S = nF \left(\frac{dE}{dt} \right) = 2 \times 96500 \times (5 \times 10^{-4} \text{ J/C}^\circ) = -96.5 \text{ kJ}$$

at 298 K

$$T\Delta S = 298 \times (-96.5 \text{ J}) = -28.8 \text{ kJ}$$

at constant T (=248 K) and pressure

$$\Delta G = \Delta H - T\Delta S$$

$$\Delta H = \Delta G + T\Delta S$$

$$= -386 - 28.8 = -412.8 \text{ kJ}$$

46. A metal on combustion in excess air forms X. X upon hydrolysis with water yields H_2O_2 and O_2 along with another product. The metal is :

- (1) Na (2) Mg (3*) Rb (4) Li

Sol. Rb form super oxides on reaction with excess air

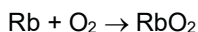

47. Water samples with BOD values of 4 ppm and 18 ppm, respectively, are :

- (1) Highly polluted and Clean (2*) Clean and Highly polluted
(3) Clean and Clean (4) Highly polluted and Highly polluted

Sol. Clean water has BOD value of less than 5 ppm and highly polluted water has a BOD value of 17 ppm or more.

48. The pair of metal ions that can give a spin only magnetic moment of 3.9 BM for the complex $[\text{M}(\text{H}_2\text{O})_6]\text{Cl}_2$ is :

- (1) V^{2+} and Fe^{2+} (2) Co^{2+} and Fe^{2+} (3*) V^{2+} and Co^{2+} (4) Cr^{2+} and Mn^{2+}

Sol. H_2O is weak field ligand and magnetic moment = Moment $\sqrt{n(n+2)}\text{BM}$

Solving for 'n' we get it as 3; i.e., no. of unpaired electron = 3

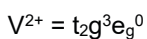
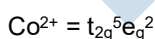
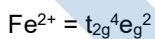

\therefore M is V, Co

49. The increasing order of reactivity of the following compounds towards reaction with alkyl halides directly is :

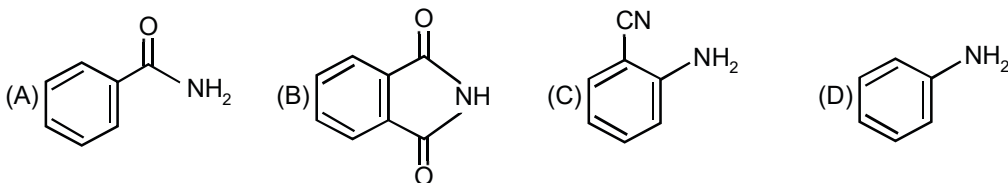

(1) (B) < (A) < (D) < (C)

(2*) (B) < (A) < (C) < (D)

(3) (A) < (B) < (C) < (D)

(4) (A) < (C) < (D) < (B)

Sol. Lone pair over nitrogen will act as the reacting centre. So, more nucleophilic nitrogen will be more reactive towards alkyl halide.

50. $Mn_2(CO)_{10}$ is an organometallic compound due to the presence of :

(1*) Mn – C bond (2) Mn – O bond (3) Mn – Mn bond (4) C – O bond

Sol. Organometallic compound contains at least one chemical bond between carbon and a metal.

51. The element with $Z = 120$ (not yet discovered) will be an / a :

(1) Inner-transition metal

(2) Transition metal

(3*) Alkaline earth metal

(4) Alkali metal

Sol. $[Og_{118}] 8s^2$ is configuration for $Z = 120$, where Og is Goransson As per the configuration it is in IInd group.

52. Iodine reacts with concentrated HNO_3 to yield Y along with other products. The oxidation state of iodine in Y, is :

(1*) 5

(2) 7

(3) 1

(4) 3

Sol. $I_2 + 10HNO_3 \rightarrow 2 HIO_3 + 10NO_2\uparrow + 4H_2O$

Iodine in HIO_3 has +5 oxidation state.

53. 50 mL of 0.5 M oxalic acid is needed to neutralize 25 mL of sodium hydroxide solution. The amount of NaOH in 50 mL of the given sodium hydroxide solution is :

(1) 80 g

(2) 20 g

(3*) 40 g

(4) 10 g

Sol. Eq. of $(COOH)_2 =$ Eq. of NaOH

$$50 \times 0.5 \times 2 = 25 \times M \times 1$$

$$\text{Mass of NaOH in 50 mL} = \frac{50 \times 2}{1000} \times 40 = 4 \text{ g}$$

54. Decomposition of X exhibits a rate constant of $0.05 \mu\text{g}/\text{year}$. How many years are required for the decomposition of $5 \mu\text{g}$ of X into $2.5 \mu\text{g}$?

(1) 40

(2) 25

(3*) 50

(4) 20

Sol. According to unit of rate constant it is a zero order reaction then half life of reaction will be

$$t_{1/2} = \frac{C_0}{2k} = \frac{5\mu\text{g}}{2 \times 0.05\mu\text{g} / \text{year}} = 50 \text{ year}$$

55. The major product of the following reaction is :

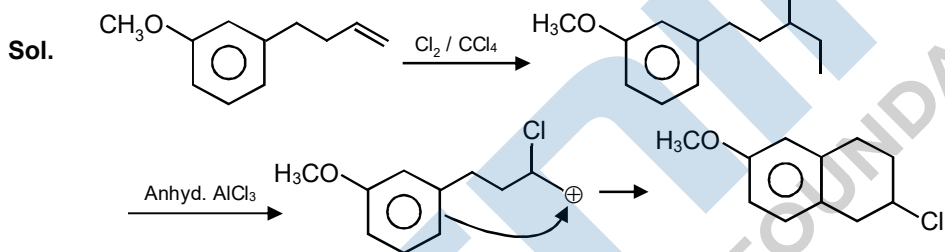
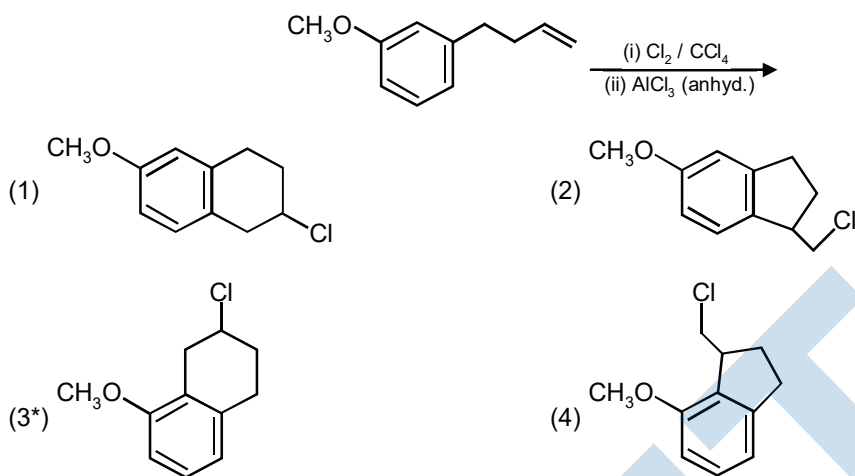

56. Given

Gas	H ₂	CH ₄	CO ₂	SO ₂
Critical Temperature / K	33	190	304	630

On the basis of data given above, predict which of the following gases shows least adsorption on a definite amount of charcoal?

- (1) H₂ (2) CH₄ (3*) SO₂ (4) CO₂

Sol. Amount of gas adsorbed \propto TC

57. In a chemical reaction, $A + 2B \rightleftharpoons 2C + D$, the initial concentrated of B was 1.5 times of the concentration of A, but the equilibrium concentrations of A and B were found to be equal. The equilibrium constant (K) for the aforesaid chemical reaction is :

- (1) $\frac{1}{4}$ (2) 1 (3) 16 (4*) 4

Sol. $A + 2B \rightleftharpoons 2C + D$
 Initially conc. $a \quad 1.5a$
 at eq. $a-x \quad 1.5(a-2x) \quad 2x \quad x$
 at equilibrium $a-x = 1.5a - 2x$
 $0.5a = x$
 $a = 2x$

$$K_c = \frac{(2x)^2 \cdot x}{(a-x)(1.5a-2x)^2} = \frac{4x^2 \cdot x}{(x)(x)^2} = 4$$

58. Among the following compounds most basic amino acid is

- (1*) Lysine (2) Serine (3) Histidine (4) Asparagine

Sol. Compound pI value
 Histidine 7.6
 Serine 5.7
 Lysine 9.8
 Asparagine 5.4

59. In the Hall-Heroult process, aluminium is formed at the cathode. The cathode is made out of :

- (1) Platinum (2) Copper (3*) Carbon (4) Pure aluminium

Sol. Cathode is made up of carbon.

60. The major product of the following reaction is :

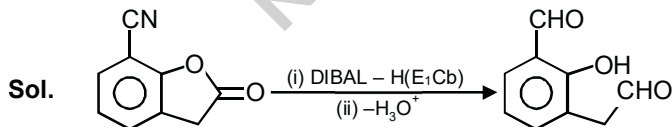
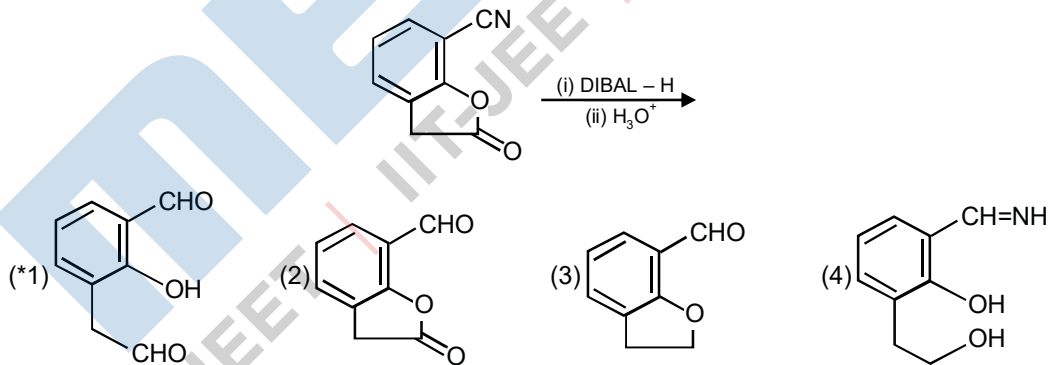

PART-C-PHYSICS

61. A point source of light, S is placed at a distance L in front of the centre of plane mirror of width d which is hanging vertically on a wall. A man walks in front of the mirror along a line parallel to the mirror, at a distance 2L as shown below. The distance over which the man can see the image of the light source in the mirror is :

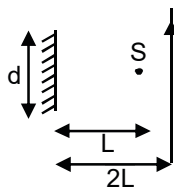

- (1*) 3d (2) d (3) $\frac{d}{2}$ (4) 2d

Sol. $h = d + \frac{d}{2} + \frac{d}{2} + d = 3d$.

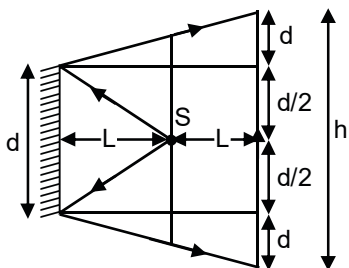

62. A particle of mass m moves in a circular orbit in a central potential field $U(r) = \frac{1}{2}kr^2$. If Bohr's quantization conditions are applied, radii of possible orbits and energy levels vary with quantum number n as :

- (1) $r_n \propto n, E_n \propto n$ (2*) $r_n \propto \sqrt{n}, E_n \propto n$ (3) $r_n \propto n^2, E_n \propto \frac{1}{n^2}$ (4) $r_n \propto \sqrt{n}, E_n \propto \frac{1}{n}$

Sol. $U = \frac{1}{2}kr^2$

Force, $F = -\frac{dU}{dr} = -kr$

For circular motion $\frac{mv^2}{r} = kr$ (i)

And $mvr = \frac{nh}{2\pi}$ (ii)

$\Rightarrow r^2 = \frac{nh}{2\pi\sqrt{km}}$

$\Rightarrow r \propto \sqrt{n}$

Total energy, $E = k + U$

$$= \frac{1}{2}mv^2 + \frac{1}{2}kr^2$$

$$= \frac{1}{2}kr^2 + \frac{1}{2}kr^2 \quad [\text{From equation (i)}]$$

$$E = kr^2$$

$$\Rightarrow \frac{r_p}{r_\alpha} = \frac{1}{\sqrt{2}}$$

63. A person standing on an open ground hears the sound of a jet aeroplane, coming from north at an angle 60° with ground level. But he finds the aeroplane right vertically above his position. If v is the speed of sound, speed of the plane is :

- (1) v (2) $\frac{\sqrt{3}}{2}v$ (3*) $\frac{v}{2}$ (4) $\frac{2v}{\sqrt{3}}$

Sol. $V_P \rightarrow$ Speed of plane

$V \rightarrow$ Speed of sound

$$V \cos 60^\circ = V_P$$

$$V_P = \frac{V}{2}$$

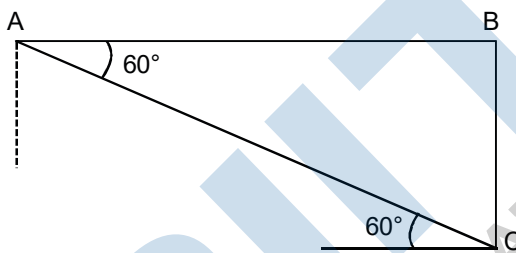

64. A simple pendulum, made of a string of length ℓ and a bob of mass m , is released from a small angle θ_0 . It strikes a block of mass M , kept on a horizontal surface at its lowest point of oscillations, elastically. It bounces back and goes up to an angle θ_1 . Then M is given by :

- (1*) $m \left(\frac{\theta_0 + \theta_1}{\theta_0 - \theta_1} \right)$ (2) $m \left(\frac{\theta_0 - \theta_1}{\theta_0 + \theta_1} \right)$ (3) $\frac{m}{2} \left(\frac{\theta_0 - \theta_1}{\theta_0 + \theta_1} \right)$ (4) $\frac{m}{2} \left(\frac{\theta_0 + \theta_1}{\theta_0 - \theta_1} \right)$

Sol. Just before collision speed of m

$$v = \sqrt{2gL(1 - \cos \theta_0)}$$

Just after collision speed of M

$$v_1 = \sqrt{2gL(1 - \cos \theta_1)}$$

$$\text{And } v_1 = \left(\frac{M - m}{M + m} \right) v ; \quad \frac{v_1}{v} = \frac{M - m}{M + m}$$

$$\frac{\sqrt{1 - \cos \theta_1}}{\sqrt{1 - \cos \theta_0}} = \frac{M - m}{M + m}$$

$$\frac{\sin(\theta_1/2)}{\sin(\theta_0/2)} = \frac{M - m}{M + m} \quad [\because 1 - \cos 2\theta = 2 \sin^2 \theta]$$

$$\frac{\theta_1}{\theta_0} = \frac{M - m}{M + m}$$

$$M\theta_1 + m\theta_1 = M\theta_0 - m\theta_0$$

$$M = m \left[\frac{\theta_1 + \theta_0}{\theta_0 - \theta_1} \right]$$

65. A cylinder of radius R is surrounded by a cylindrical shell of inner radius R and outer radius $2R$. The thermal conductivity of the material of the inner cylinder is K_1 and that of the outer cylinder is K_2 . Assuming no loss of heat, the effective thermal conductivity of the system for heat flowing along the length of the cylinder is :

(1*) $\frac{K_1 + 3K_2}{4}$ (2) $\frac{K_1 + K_2}{2}$ (3) $K_1 + K_2$ (4) $\frac{2K_1 + 3K_2}{5}$

Sol. Equivalent thermal resistance.

$$\frac{1}{R} = \frac{1}{R_1} + \frac{1}{R_2}$$

$$\frac{k\pi(2R)^2}{L} = \frac{k_1\pi R^2}{L} + \frac{k_2\pi[(2R)^2 - R^2]}{L}$$

$$\Rightarrow 4k = k_1 + 3k_2$$

$$\Rightarrow k = \frac{k_1 + 3k_2}{4}$$

66. As shown in the figure, two infinitely long, identical wires are bent by 90° and placed in such a way that the segments LP and QM are along the x -axis, while segments PS and QN are parallel to the y -axis. If $OP = OQ = 4\text{cm}$, and the magnitude of the magnetic field at O is 10^{-4} T , and the two wires carry equal currents (see figure), the magnitude of the current in each wire and the direction of the magnetic field at O will be ($\mu_0 = 4\pi \times 10^{-7}\text{ NA}^{-2}$) :

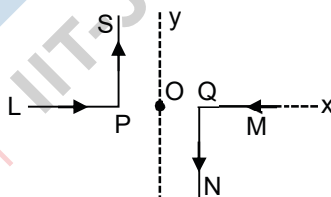

- (1*) 20 A, perpendicular into the page (2) 20 A, perpendicular out of the page
 (3) 40A, perpendicular into the page (4) 40A, perpendicular out of the page

Sol. $B = 2 \left[\frac{\mu_0 i}{4\pi d} (\cos\theta_1 - \cos\theta_2) \right]$

$$B = 10^{-4} \qquad \theta_1 = 90^\circ$$

$$\mu_0 = 4\pi \times 10^{-7} \qquad \theta_2 = 180^\circ$$

$$d = 4 \times 10^{-2}$$

$$\Rightarrow i = 20\text{ A (into the page)}$$

67. The position vector of the centre of mass \vec{r}_{cm} of an asymmetric uniform bar of negligible area of cross-section as shown in figure is

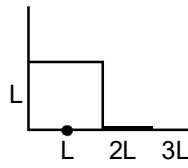

- (1) $\vec{r}_{cm} = \frac{11}{8}L\hat{x} + \frac{3}{8}L\hat{y}$ (2) $\vec{r}_{cm} = \frac{3}{8}L\hat{x} + \frac{11}{8}L\hat{y}$
 (3*) $\vec{r}_{cm} = \frac{13}{8}L\hat{x} + \frac{5}{8}L\hat{y}$ (4) $\vec{r}_{cm} = \frac{5}{8}L\hat{x} + \frac{13}{8}L\hat{y}$

Sol. Three parts of rod can be considered as point masses.

$$\vec{r}_{cm} = \frac{2m\vec{r}_1 + m\vec{r}_2 + m\vec{r}_3}{4m}$$

$$\vec{r}_{cm} = \frac{2m(L\hat{i} + L\hat{j}) + m\left(2L\hat{i} + \frac{L}{2}\hat{j}\right) + m\left(\frac{5L}{2}\hat{i}\right)}{4m}$$

$$= \frac{\frac{13}{2}L\hat{i} + \frac{5}{2}L\hat{j}}{4}$$

$$= \frac{13}{2}L\hat{i} + \frac{5}{8}L\hat{j}$$

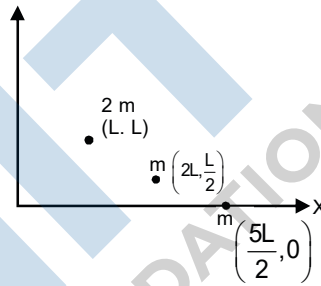

68. Two electric bulbs, rated at (25 W, 220 V) and (100 W, 220 V), are connected in series across a 220V voltage source. If the 25 W and 100 W bulbs draw powers P_1 and P_2 respectively, then :

- (1) $P_1 = 9 \text{ W}, P_2 = 16 \text{ W}$ (2) $P_1 = 4 \text{ W}, P_2 = 16 \text{ W}$
 (3) $P_1 = 16 \text{ W}, P_2 = 9 \text{ W}$ (4*) $P_1 = 16 \text{ W}, P_2 = 4 \text{ W}$

Sol. Resistance, $R = \frac{V^2}{P}$

$$\Rightarrow R_1 = \frac{(220)^2}{25} = 1936\Omega$$

$$R_2 = \frac{(220)^2}{100} = 484\Omega$$

$$i = \frac{220}{R_1 + R_2} = \frac{1}{11} \text{ A}$$

Power dissipated through $R_1 = P_1 = i^2R_1 = 16 \text{ W}$

Power dissipated through $R_2 = P_2 = i^2R_2 = 4 \text{ W}$

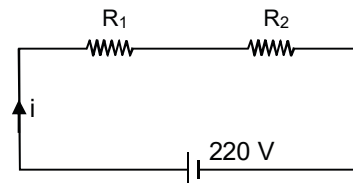

69. A passenger train of length 60 m travels at a speed of 80 km/hr. Another freight train of length 120 m travels at a speed of 30 km/hr. The ratio of times taken by the passenger train to completely cross the freight train when : (i) they are moving in the same direction, and (ii) in the opposite directions is:

- (1) $\frac{3}{2}$ (2) $\frac{25}{11}$ (3*) $\frac{11}{5}$ (4) $\frac{5}{2}$

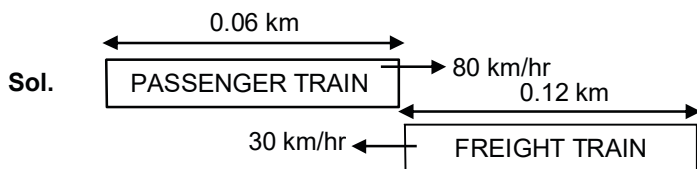

Time taken if both moving in same direction

$$t_1 = \frac{\text{distance}}{\text{speed}} = \frac{0.12 + 0.06}{80 - 30} = \frac{0.18}{50}$$

Time taken if moving in opposite direction.

$$t_2 = \frac{\text{distance}}{\text{speed}} = \frac{0.12 + 0.06}{80 + 30} = \frac{0.18}{110}$$

$$\frac{t_1}{t_2} = \frac{11}{5}$$

70. for the given cyclic process CAB as shown for a gas, the work done is

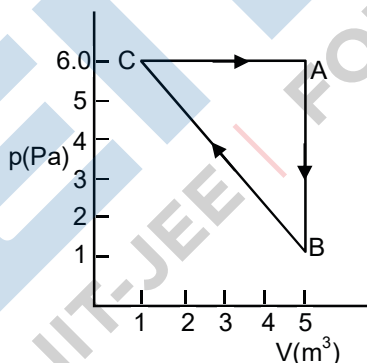

- (1*) 10 J (2) 1 J (3) 5 J (4) 30 J

Sol. Work done = Area of loop

$$= \frac{1}{2}(4)(5) = 10 \text{ J}$$

71. A travelling harmonic wave is represented by the equation $y(x, t) = 10^{-3} \sin(50t + 2x)$, where x and y are in meter and t is in seconds. Which of the following is a correct statement about the wave?

- (1) The wave is propagating along the positive x -axis with speed 25 ms^{-1}
 (2) The wave is propagating along the negative x -axis with speed 100 ms^{-1}
 (3) The wave is propagating along the positive x -axis with speed 100 ms^{-1}

(4*) The wave is propagating along the negative x-axis with speed 25 ms^{-1}

Sol. $y = 10^{-3} \sin (50t + 2x)$

Wave is travelling along negative x-axis

Wave speed = $\frac{\omega}{k} = \frac{50}{2} = 25 \text{ m/s}$.

72. The least count of the main scale of a screw gauge is 1 mm. The minimum number of divisions on its circular scale required to measure $5 \mu\text{m}$ diameter of a wire is

- (1) 100 (2*) 200 (3) 500 (4) 50

Sol. Least count = $\frac{\text{Pitch}}{\text{No. of divisions on circular scale}}$

$5 \times 10^{-6} = \frac{10^{-3}}{N}$

$N = 200$

73. Determine the electric dipole moment of the system of three charges, placed on the vertices of an equilateral triangle, as shown in the figure:

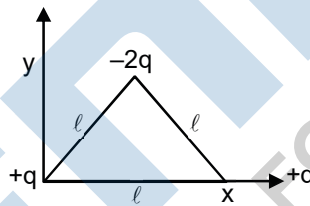

- (1) $\sqrt{3}q\ell \frac{\hat{j}-\hat{i}}{\sqrt{2}}$ (2) $2q\ell \hat{j}$ (3) $(q\ell) \frac{\hat{i}+\hat{j}}{\sqrt{2}}$ (4) $-\sqrt{3}q\ell \hat{j}$

Ans. Bonus

Correction Ans. $-\sqrt{3}q\ell \hat{j}$

Sol. $|\vec{P}| = qL$

$\vec{P}_{\text{net}} = 2P \cos 30^\circ (-\hat{j})$

$= P\sqrt{3} (-\hat{j})$

$= \sqrt{3}qL (-\hat{j})$

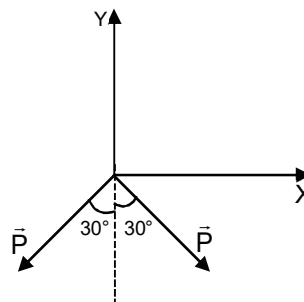

74. A satellite of mass M is in a circular orbit of radius R about the centre of the earth. A meteorite of the same mass, falling towards the earth, collides with the satellite completely inelastically. The speed of the satellite and the meteorite are the same, just before the collision. The subsequent motion of the combined body will be:

- (1) In the same circular orbit of radius R
- (2) Such that it escapes to infinity
- (3*) In an elliptical orbit
- (4) In a circular orbit of a different radius

Sol. $2mv_x = mv$

$$\Rightarrow v_x = \frac{v}{2}$$

$$v_y = \frac{v}{2}$$

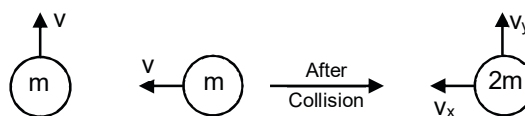

$$V_{net} = \sqrt{v_x^2 + v_y^2} = \frac{v}{\sqrt{2}}$$

So, path will be elliptical.

75. What is the position and nature of image formed by lens combination shown in figure? (f_1, f_2 are focal lengths)

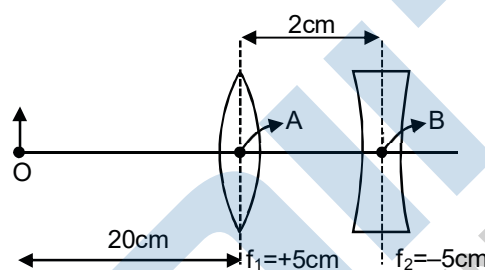

- (1*) 70 cm from point B at right; real
- (2) 70 cm from point B at left; virtual
- (3) $\frac{20}{3}$ cm from point B at right, real
- (4) 40 cm from point B at right; real

Sol. image by convex lens:

$$\frac{15}{v} - \frac{1}{u} = \frac{1}{f} ; \quad \frac{1}{v} + \frac{1}{20} = \frac{1}{5}$$

$$v = \frac{20}{3} \text{ cm}$$

Image by concave lens:

$$u = \left[\frac{20}{3} - 2 \right] = \frac{14}{3} \text{ cm}$$

$$\frac{1}{v} - \frac{1}{u} = \frac{1}{f} ; \quad \frac{1}{v} - \frac{3}{14} = -\frac{1}{5}$$

$$v = 70 \text{ cm}$$

76. Let the moment of inertia of a hollow cylinder of length 30 cm (inner radius 10 cm and outer radius 20 cm), about its axis be I. The radius of a thin cylinder of the same mass such that its moment of inertia about its axis is also I, is:

- (1*) 16 cm (2) 14 cm (3) 18 cm (4) 12 cm

Sol. $r = 10$ cm mass per unit
 $R = 20$ area

Mass = m $\sigma = \frac{m}{\pi(R^2 - r^2)}$

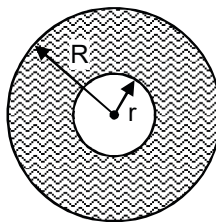

Consider an element of radius x and thickness dx

Mass of element $dm = \sigma 2\pi x(dx)$

Moment of inertia of element, $dt = (dm)x^2$

$$\Rightarrow I = \sigma 2\pi \int_r^R x^3 dx$$

$$= \sigma \frac{2\pi}{4} (R^4 - r^4)$$

$$= \frac{m}{\pi(R^4 - r^2)} \frac{\pi}{2} (R^4 - r^4)$$

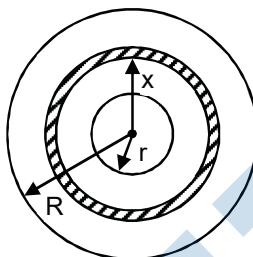

$$I = \frac{m}{2} (R^2 + r^2) \dots\dots\dots(i)$$

Moment of inertia of thin cylinder of same mass,

$$I = mr_0^2 \dots\dots\dots(ii)$$

$$\Rightarrow mr_0^2 = \frac{m}{2} (R^2 + r^2)$$

$$r_0^2 = 250 \quad ; \quad r_0 \approx 16 \text{ cm.}$$

77. In a meter bridge, the wire of length 1m has a non-uniform cross-section such that, the variation $\frac{dR}{d\ell}$ of its resistance R with length ℓ is $\frac{dR}{d\ell} \propto \frac{1}{\sqrt{\ell}}$. Two equal resistances are connected as shown in the figure.

The galvanometer has zero deflection when the jockey is at point P. What is the length AP?

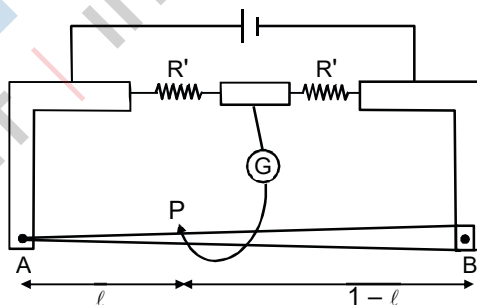

- (1*) 0.25 m (2) 0.3 m (3) 0.2 m (4) 0.35 m

Sol. $\frac{dR}{d\ell} = \frac{k}{\sqrt{\ell}}$ $k = \text{constant}$

$$\int_0^R dR = k \int_0^L \frac{d\ell}{\sqrt{\ell}}$$

$R = 2k$ resistance of wire AB.

Again, $\int_0^{R/2} dR = k \int_0^L \frac{d\ell}{\sqrt{\ell}}$ $L \rightarrow$ Length AP

$$\frac{R}{2} = k2L^{1/2} \quad ; \quad k = k2 \quad L^{1/2}$$

$$\Rightarrow L = \frac{1}{4} \text{ m} = 0.25 \text{ m}$$

78. Two light identical springs of spring constant k are attached horizontally at the two ends of a uniform horizontal rod AB of length ℓ and mass m . The rod is pivoted at its centre 'O' and can rotate freely in horizontal plane. The other ends of the two springs are fixed to rigid supports as shown in figure. The rod is gently pushed through a small angle and released. The frequency of resulting oscillation is:

(1*) $\frac{1}{2\pi} \sqrt{\frac{6k}{m}}$

(2) $\frac{1}{2\pi} \sqrt{\frac{3k}{m}}$

(3) $\frac{1}{2\pi} \sqrt{\frac{k}{m}}$

(4) $\frac{1}{2\pi} \sqrt{\frac{2k}{m}}$

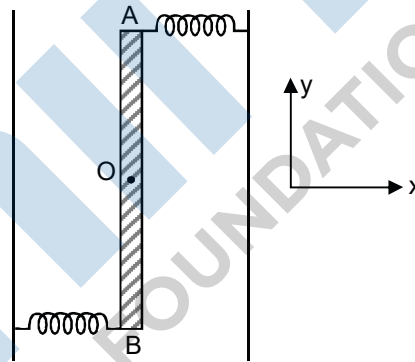

Sol. Torque on rod at displacement θ from mean position θ is very small.

$$x = \frac{L}{2} \theta$$

$$\tau = 2kx \frac{L}{2} = 2k \frac{L^2}{4} \theta = \frac{kL^2}{2} \theta$$

Now, $\tau = I\alpha$

$$\frac{kL^2}{2} \theta = \frac{mL^2}{12} \alpha \quad ; \quad \alpha = \frac{6k}{m} \theta$$

$$\tau = \frac{\omega}{2\pi} = \frac{1}{2\pi} \sqrt{\frac{6k}{m}}$$

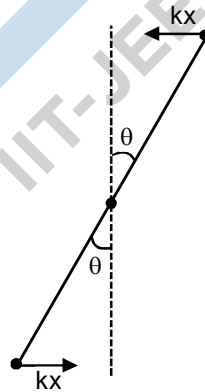

79. A proton and an α -particle (with their masses in the ratio of 1 : 4 and charges in the ratio of 1 : 2) are accelerated from rest through a potential difference V . If a uniform magnetic field (B) is set up perpendicular to their velocities, the ratio of the radii $r_p : r_\alpha$ of the circular paths described by them will be:

(1) $1 : \sqrt{3}$

(2) $1 : 2$

(3) $1 : 3$

(4*) $1 : \sqrt{2}$

Sol. $m_p = m$ $q_p = q$ $k_p = qV = k$
 $m_\alpha = 4m$ $q_\alpha = 2q$ $k_\alpha = 2qV = 2k$

Radius of circular path,

Radius of circular path,

$$r = \frac{mv}{qB} = \frac{\sqrt{2km}}{qB}$$

$$\Rightarrow \frac{r_p}{r_\alpha} = \frac{1}{\sqrt{2}}$$

80. A straight rod of length L extends from $x = a$ to $x = L + a$. The gravitational force it exerts on a point mass 'm' at $x = 0$, if the mass per unit length of the rod is $A + Bx^2$, is given by :

(1) $Gm \left[A \left(\frac{1}{a+L} - \frac{1}{a} \right) + BL \right]$

(2*) $Gm \left[A \left(\frac{1}{a} - \frac{1}{a+L} \right) + BL \right]$

(3) $Gm \left[A \left(\frac{1}{a} - \frac{1}{a+L} \right) - BL \right]$

(4) $Gm \left[A \left(\frac{1}{a+L} - \frac{1}{a} \right) - BL \right]$

Sol.

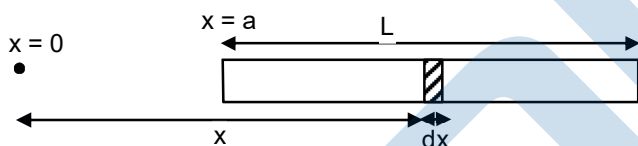

Mass of element = $dm = (A + Bx^2)dx$

Field due to element at $x = 0$

$$dE = \frac{G(dm)}{x^2} = \left(\frac{GA}{x^2} + GB \right) dx$$

Total field

$$E = GA \int_a^{a+L} \frac{1}{x^2} dx + GB \int_a^{a+L} dx$$

$$= G \left[A \left(\frac{1}{a} - \frac{1}{a+L} \right) + BL \right]$$

So, force = mE

$$= Gm \left[A \left(\frac{1}{a} - \frac{1}{a+L} \right) + BL \right]$$

81. A light wave is incident normally on a glass slab of refractive index 1.5. If 4% of light gets reflected and the amplitude of the electric field of the incident light is 30 V/m, then the amplitude of the electric field for the wave propagating in the glass medium will be :

(1) 30 V/m

(2) 6 V/m

(3*) 24 V/m

(4) 10 V/m

Sol. $I = \frac{1}{2} \epsilon_0 E_0^2 C$ (i)

$0.96 I = \frac{1}{2} E_0^2 V$ (ii)

$\Rightarrow 0.96 = \left(\frac{E_0'}{E_0}\right)^2 \frac{\epsilon v}{\epsilon_0 C}$

$0.96 = \left(\frac{E_0'}{E_0}\right)^2 \frac{\epsilon}{\epsilon_0} \frac{1}{1.5}$

$0.96 = \left(\frac{E_0'}{E_0}\right)^2 \epsilon_r \frac{1}{1.5}$ (iii)

and $v = \frac{1}{\sqrt{\mu_0 \epsilon_0 \mu_r \epsilon_r}}$; $v = \frac{C}{\sqrt{\mu_r \epsilon_r}}$

$\sqrt{\mu_r \epsilon_r} = \frac{C}{v}$; $\sqrt{\epsilon_r} = 1.5$; $\mu_r \approx 1$ for transparent medium.

Form equation (iii)

$0.96 = \left(\frac{E_0'}{E_0}\right)^2 (1.5)^2 \left(\frac{1}{1.5}\right)$

$\Rightarrow E_0' = 24 \text{ V/m}$

82. A particle A of mass 'm' and charge 'q' is accelerated by a potential difference of 50V. Another particle B of mass '4m' and charge 'q' is accelerated by a potential difference of 2500 V. The ratio of de-Broglie wavelengths $\frac{\lambda_A}{\lambda_B}$ is close to :

(1) 10.00

(2) 0.07

(3*) 14.14

(4) 4.47

Sol. $\lambda = \frac{h}{\sqrt{2mqV}}$

$\frac{\lambda_p}{\lambda_\alpha} = \sqrt{\frac{4 \times 1 \times 2500}{1 \times 1 \times 50}} = 10\sqrt{2} = 14.14$

83. The galvanometer deflection, when key K_1 is closed but K_2 is open, equal θ_0 (see figure). On closing K_2 also and adjusting R_2 to 5Ω , the deflection in galvanometer becomes $\frac{\theta_0}{5}$. The resistance of the galvanometer is, then, given by [neglect the internal resistance of battery]

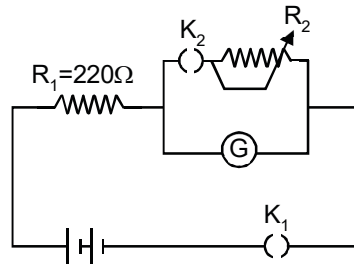

- (1) 5 Ω (2) 12 Ω (3*) 22 Ω (4) 25 Ω

Sol. When K_1 closed and K_2 is open

$$i = \frac{V}{220 + R} \dots\dots(i)$$

When k_1 and k_2 are closed.]

KCL →

$$\left(\frac{iR}{25} + \frac{i}{5}\right)220 + \frac{i}{5}R = V$$

$$\left(\frac{iR}{25} + \frac{i}{5}\right)220 + \frac{i}{5}R = i(220 + R) \text{ From eq. (i)}$$

$$\Rightarrow R = 22 \Omega$$

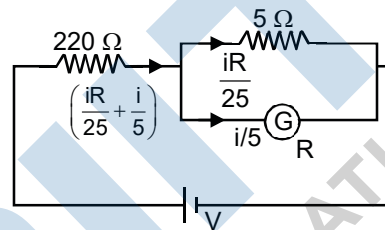
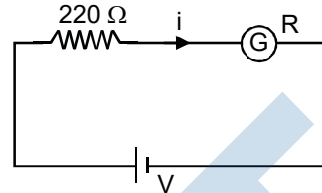

84. An ideal gas occupies a volume of $2m^3$ at a pressure of 3×10^6 Pa. The energy of the gas is :

- (1) 3×10^2 J (2) 10^8 J (3*) 9×10^6 J (4) 6×10^4 J

Sol. Cannot determine, degree of freedom must be given.

85. There is a uniform spherically symmetric surface charge density at a distance R_0 from the origin. The charge distribution is initially at rest and starts expanding because of mutual repulsion. The figure that represents best the speed $V(R(t))$ of the distribution as a function of its instantaneous radius $R(t)$ is :

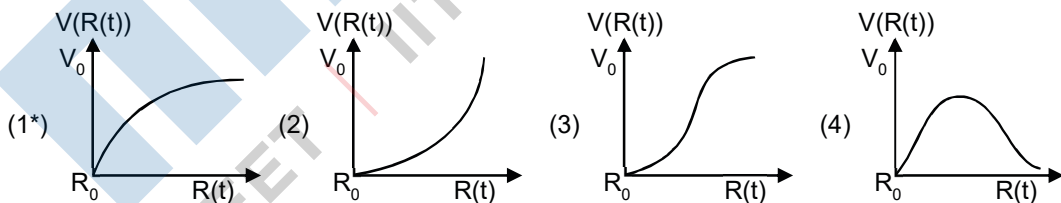

Sol. $U_i + K_i = U_f + K_f$

$$\frac{kQ^2}{2R_0} + 0 = \frac{kQ^2}{2R} + \frac{1}{2}mv^2$$

$$V = \sqrt{\frac{kQ^2}{m} \left(\frac{1}{R_0} - \frac{1}{R} \right)}$$

86. In the figure shown, after the switch 'S' is turned from position 'A' to position 'B', the energy dissipated in the circuit in terms of capacitance 'C' and total charge 'Q' is:

(1) $\frac{1}{8} \frac{Q^2}{C}$

(2*) $\frac{3}{8} \frac{Q^2}{C}$

(3) $\frac{5}{8} \frac{Q^2}{C}$

(4) $\frac{3}{4} \frac{Q^2}{C}$

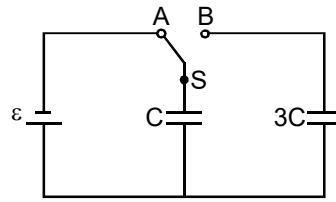

Sol. Before switch is shifted:

Energy stored,

$$U_i = \frac{1}{2} CE^2$$

and charge stored,

$$Q = CE$$

After switch is shifted:

$$V_M - V_N = \frac{Q}{4C} = \frac{CE}{4C} = \frac{E}{4}$$

$$\text{Energy stored, } U_f = \frac{1}{2} (4C) \left(\frac{E}{4} \right)^2 = \frac{1}{8} CE^2$$

$$\text{Energy dissipated} = U_i - U_f = \frac{3}{8} CE^2$$

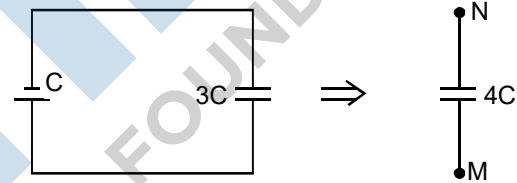

87. The output of the given logic circuit is :

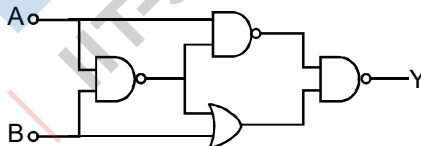

(1*) $A\bar{B}$

(2) $AB + \bar{A}\bar{B}$

(3) $A\bar{B} + \bar{A}B$

(4) $\bar{A}B$

Sol. $Y = A.\bar{A}B + AB.\bar{B}$

$$= A.(\bar{A} + \bar{B}) + (AB).\bar{B}$$

$$= A\bar{B} + 0$$

88. R are connected in series in the primary circuit of a potentiometer of length 1m and resistance 5Ω . The value of R, to give a potential difference of 5 mV across 10 cm of potentiometer wire, is

- (1*) 395 Ω (2) 495 Ω (3) 490 Ω (4) 480 Ω

Sol. $i = \frac{4}{5+R}$

$$V_{AB} = i(5) = \frac{20}{5+R}$$

$$V_{AP} = \frac{V_{AB}}{L}(0.1) = \frac{20}{5+R} \left(\frac{0.1}{1} \right) = \frac{2}{5+R}$$

Now, $\frac{2}{5+R} = 5 \times 10^{-3}$

$\Rightarrow R = 395 \Omega$

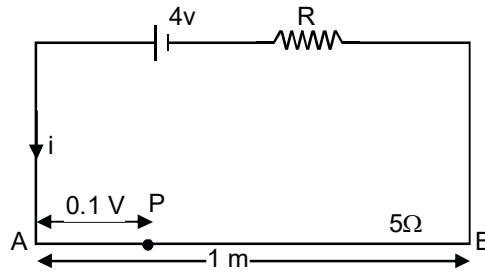

89. In the figure shown, a circuit contains two identical resistors with resistance $R = 5\Omega$ and an inductance with $L = 2\text{mH}$. An ideal battery of 15 V is connected in the circuit. What will be the current through the battery long after the switch is closed?

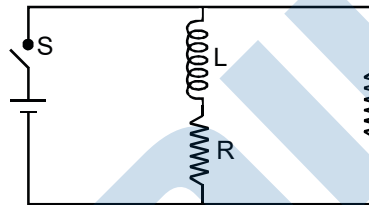

- (1) 7.5 A (2) 5.5 A (3) 3 A (4*) 6 A

Sol. After long time, inductor will behave like resistance less wire,

$$i = \frac{15}{R_{eq}} = \frac{15}{(5-12)}$$

$$= 6 \text{ A}$$

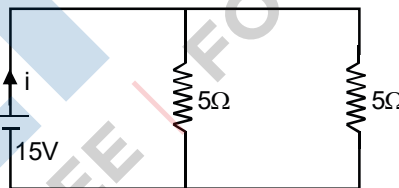

90. A 100 V carrier wave is made to vary between 160 V and 40 V by a modulating signal. What is the modulation index?

- (1) 0.4 (2*) 0.6 (3) 0.3 (4) 0.5

Sol. $A_c = 100$

$$A_c + A_m = 160$$

$$A_c - A_m = 40$$

$A_c = 100, A_m = 60$

$$\mu = \frac{A_m}{A_c} = 0.6$$